

MP AGM Batteries Range

79AH 12V

Century MP range is designed to operate for a range of materials handling equipment applications. The Century MP range uses AGM technology which ensures that there is no 'free acid' in the battery. This allows the battery to be mounted either vertically or horizontally. In addition, the battery uses a heavy duty lead calcium tin alloy grid construction – generating less gassing and reduced self-discharge. This allows the Century MP range the ability to perform reliably in material handling applications for a minimum of 12 months. Their reliable performance is a testament to Century Yuasa's years of dedicated research, design and testing combined with its local quality assurance programs.

Features and Benefits

- Oxygen recombination technology – low maintenance
- Special grid alloy – less gassing and less self discharging
- Longer cycle life – special paste formula and optimised manufacturing process with additives for deep discharge
- High quality AGM separator – extend cycle life and prevents micro short circuit within the battery
- ABS case material – increased durability against impact



Representation only

MP AGM Batteries Range

79AH 12V

SPECIFICATIONS		
Century Part Number	148111	
Nominal Voltage	12V	
Nominal Capacity (20hr)	95.0AH	
Nominal Capacity (5hr)	79.0AH	
Approx Weight	27kg	
Terminal	M6 bolt – on insert	
Container material	ABS	
Max. Discharge Current	1080A (5 seconds)	
Internal Resistance	5 mOhms	
Cycle Use	Initial charging current less than 27A Charge voltage 14.4VDC (2.4VPC) @ 25°C	
Capacity affected by temperature	40°C	103%
	25°C	100%
	0°C	86%
Self Discharge	Batteries may be stored for up to 6 months at 25°C and then a freshening charge is required. For higher temperatures the time interval will be shorter.	

RATED CAPACITY			
95.0AH/4.75A	20hr	1.80V/Cell	25°C
90.0AH/9.0A	10hr	1.80V/Cell	25°C
79.0AH/15.8A	5hr	1.75V/Cell	25°C
71.7AH/23.9A	3hr	1.75V/Cell	25°C
58.1AH/58.1A	1hr	1.60V/Cell	25°C

OPERATING TEMPERATURE RANGE			
	Discharge	Charge	Storage
From	-15°C	0°C	-15°C
To	+50°C	+40°C	+40°C
Nominal	25±3°C	25±3°C	25±3°C

DIMENSIONS		
Length	Width	Overall height
305mm±2mm	168mm±2mm	213mm±2mm

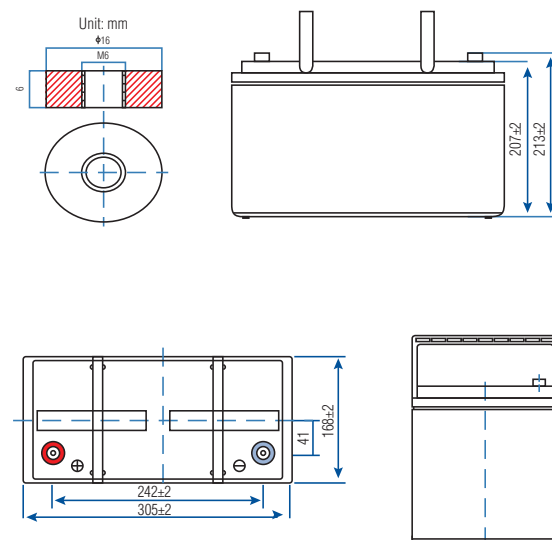

Product Specification Disclaimer

All reasonable care has been taken to ensure that the data presented in this document is accurate for the purpose for which it is presented. CenturyYuasa reserves the right to make changes to its products and information contained in this document without notice, and shall not be held liable for any loss or damage claimed to have arisen as a result of the use of this brochure.

An affiliated business of the GS Yuasa Corporation, CenturyYuasa has over 80 years of supplying a range of stored energy solutions to the Australian and New Zealand market. An established network of sales and distribution offices throughout Australia and New Zealand has seen the business gain the trust and respect from its customers by focusing on quality products and exceptional customer service.

The portfolio within CenturyYuasa includes a wide range of stored energy products and services, as well as identifiable brands and unique technologies for automotive, materials handling and standby power applications. Directly maintaining and operating manufacturing centers in Australia and employing some 500 people, CenturyYuasa continues to be the Regions leading manufacturer of stored energy products.